

Experiment# 3: Study of a DL OR and DTL NOR gate

CKT diagram

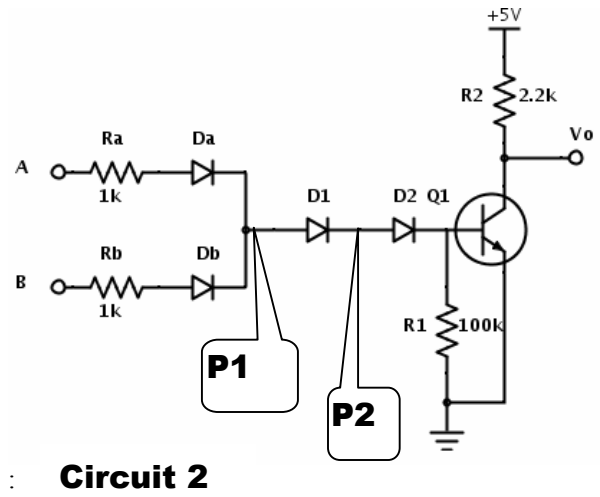
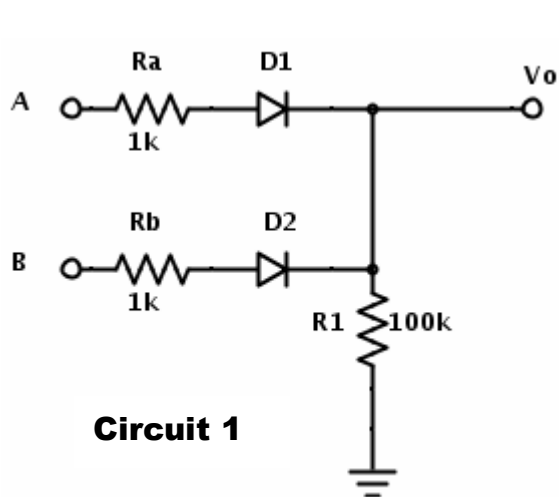

Components Required

- | | | | |
|---------------------------|-------|------------------|-------|
| 1. Transistor BD135 | 1 pc | 3. Resistor 100k | 2 pcs |
| 2. Doide 1N4001 or 1N4007 | 4 pcs | 4. Resistor 2.2k | 1 pc |
| | | 5. Resistor 1k | 2 pcs |

Procedure:

1. Implement circuit 1.
2. Apply 0v and/or 5v as input to ports A and B.
3. Measure output voltage V_o for all input combinations

4. Implement circuit 2.
5. Apply 0v and/or 5v as input to ports A and B.
6. Measure (i) output voltage V_o and (ii) voltages at points P1, P2 and at the base of the transistor for all input combinations.

Questions:

1. Using experimental data, analyse both the circuits for both positive and negative logic..
2. Why are the diodes D1 and D2 been used? Explain using experimental data.

Report:

Report should cover the following points:

1. Objective
2. Circuit Diagram
3. Experimental Data
4. Calculations if any.
5. Answer to the questions
6. Discussion of the findings